

Poppy Table

BY ROBERT W. LANG



Before developing the rectilinear Craftsman style, Gustav Stickley experimented with curvaceous Art Nouveau designs.

Fresh look from an old design. This small tea table was originally made more than 100 years ago by Gustav Stickley. His sense of proportion and design was not limited to straight lines.

This plan brought to you by:



Published in **Popular Woodworking Magazine.**
www.popularwoodworking.com

In 1898, Gustav Stickley took a working vacation. With more than 20 years of experience as a furniture maker, he was ready to change direction, and he headed across the Atlantic Ocean for inspiration. The Arts & Crafts movement was strong in England, while in France the latest thing was L'Art Nouveau.

In 1900 Stickley debuted several new designs marketed as "New Furniture" by the Tobey company of Chicago. This table was one of the most striking of those pieces, heavily influenced by Art Nouveau and a far cry from the rectilinear designs of the Craftsman style furniture he would become best known for.

There is a hint of things to come, however. The edges of the top, shelf and legs are all sinuous curves, but the surfaces are essentially flat, and the corners are just barely broken. It also presents an interesting engineering problem. Beneath the carved surfaces and waving edges, the table is based on a pentagon, so the angles between the stretchers, shelf and five legs are at 72°, not 90°.

This "Poppy Table" has been on my to-do list for a long time, and when I came across some good photos from an auction, I decided that the time was right to go ahead.

Engineering First

When I began working on the design, my first concern was the shape of the pieces. I soon realized that this project would also be a structural challenge. In the original, face-grain plugs are visible on the outside of the legs, centered on the shelf. Usually this means a screw is beneath the plug, but it seemed to me that these joints needed more than a mechanical fastener.

I don't really know how the original is held together at the intersection of the leg and shelf. Loose tenons seem the obvious solution to us today, but at the time a dowel or two flanking the screw would have been more likely. I decided to use Festool Dominos for loose tenons, along with a screw to pull the assembly together. It's hard to clamp a pentagon.

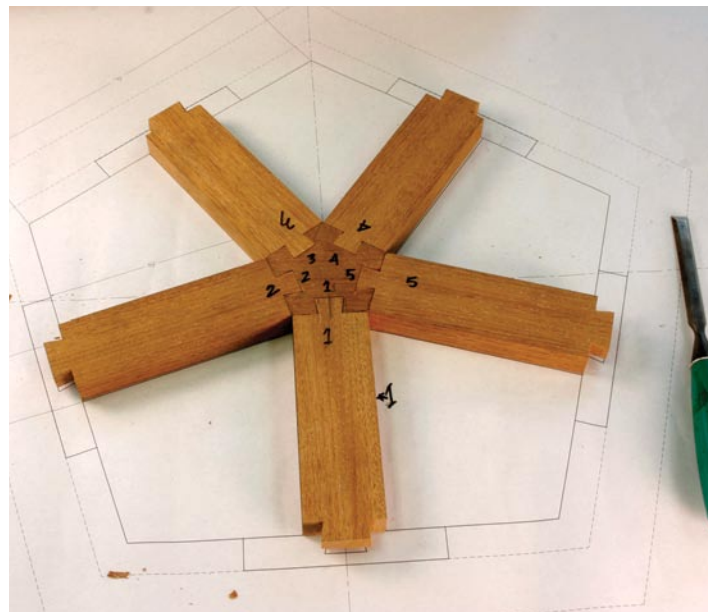

Following the plan. A full-size layout aids in making the parts and the joints accurately. As the table was assembled, I compared the actual pieces to the lines on the drawing.

At the top of the legs, stretchers seemed necessary, but it was a puzzle deciding how to connect them to the legs. There isn't any structure visible in the photo I was working from, so my solution is a best guess. I used a lapped dovetail at each end of the 2"-wide stretchers, and in the center made a five-sided hub piece that holds them all together.

Together Twice to Make it Nice

All the parts for this table came from a single plank of mahogany about 14" wide and 12' long. I made all the joints and dry-assembled the entire table before doing any of the decorative work.

The hub is the piece I worried most about. It is like a keystone that affects the location of the other joints. Any variations in this piece and the legs would twist and throw off the joints at the shelf. Because it was too small to safely cut on the table saw or miter saw, I cut it on the band saw. I then made a small shooting board, shown in the photo below, and trimmed the hub to size with a low-angle block plane.

I made a full-size printout of my drawing (you can purchase one for download online at popularwoodworking.com/dec07 for \$3, or create one yourself using the scale drawings on page 39) and used that to check the parts



The hub is the keystone. All of the structural parts of the table radiate from this small piece, so it needs to be precise. This shooting jig lets me trim it down in tiny increments.



Hidden lapped dovetails. The stretchers connect to the hub and the leg with 1/2"-thick lapped dovetails. They are 3/4" wide at the hub end and 1" wide at the leg.



Never to be seen. These joints won't show in the finished table, but they must be strong. The sockets in the legs were wasted with a small router; the sockets in the hub with a Forstner bit. I then pared them all to size with a chisel.

and assemblies as I made them. I cut a rabbet at each end of the stretchers with a tenoning jig on the table saw, leaving $\frac{1}{2}$ " thickness for the dovetails. I hand cut the dovetails and used them to lay out the sockets in the hub and the top of each leg. Numbering each stretcher and its hub location helped keep the parts in order.

Because the hub was so small, I couldn't use a router to remove the waste for the sockets, so I used a Forstner bit at the drill press to establish the flat bottom of the sockets and cleaned up the sides with a chisel. For the sockets in the legs, at the other end of the stretchers, I used a $\frac{1}{4}$ " spiral upcut bit in a small router with a fence to cut a smooth bottom and back for each socket. Again, I cleaned up the corners with a chisel.

Then I dry-fit the hub to the stretchers, and test-fit the assembled hub and stretchers to the legs. After a bit of tweaking to the joints, I glued the stretchers to the hub, but left the stretcher-to-leg joints loose.

I cut the shelf to size, and made sure that it fit the perimeter of the legs and assembled top hub. I centered a Domino in each edge of the shelf at the maximum depth and at the center of each leg at the minimum depth, with the top of the shelf $7\frac{1}{8}$ " above the bottom of the leg. I glued the Dominos into the shelf only, drilled a counterbored hole and drove a #8 x $1\frac{1}{2}$ " screw through each leg and into the tenons in the shelf.



Straight fitting. All the joints were made and all parts dry-assembled before doing any of the shaping to the legs and shelf.

After squaring up the shelf and legs, I was ready to cut the parts to final shape. When I was satisfied that everything was tight and square, I took it apart to cut the profiles.

The Shape of Things

I used spray adhesive to glue full-size paper patterns to the blanks for the shelf and top. I also glued a full-size pattern to a piece of $\frac{1}{2}$ " Baltic birch plywood to make a template for the legs. The top and shelf were cut to shape at the band saw. Where the shelf meets the legs, I left a flat area in the curve for the joint. I ended the curves about $\frac{1}{2}$ " away from the intersections with the legs so I could trim right to the meeting point after the legs were shaped and smoothed.

The plywood pattern I made for the legs has the pattern on only one side. After cutting the pattern just outside the lines on the band saw, I smoothed the plywood edges back to the lines with a rasp.

I marked one side of each leg, then flipped the pattern over to mirror the outline on the vertical centerline. This saved some time in making the pattern, and it ensured that the legs would be symmetrical.



Rapid layout. Gluing a full-size paper pattern to the shelf blank eliminates transferring the pattern. The paper will stay in place through the cutting process.



Taking a stab at marking. Cutting through the pattern with the point of a knife establishes the layout lines for the carving.

After cutting the outside shape of the legs at the band saw, I drilled holes near the ends of the cutouts, and I used a jigsaw with a narrow blade to rough-cut the shapes. I clamped the pattern to the legs, then trimmed the outside edges and the cutouts with a $\frac{1}{4}$ "-diameter flush-cutting bit in a small router.

Stickley Poppy Table

NO.	ITEM	DIMENSIONS (INCHES)			MATERIAL	COMMENTS
		T	W	L		
1	Top	13/16	21 ³ / ₁₆	22 ⁵ / ₁₆	Mahogany	
1	Shelf	13/16	16 ¹ / ₁₆	16 ⁷ / ₈	Mahogany	
5	Legs	13/16	4 ⁷ / ₈	22 ¹¹ / ₁₆	Mahogany	
1	Hub	13/16	3 ¹ / ₁₆	3 ¹ / ₄	Mahogany	
5	Stretchers	13/16	2	6 ¹³ / ₁₆	Mahogany	1/2" dovetail both ends

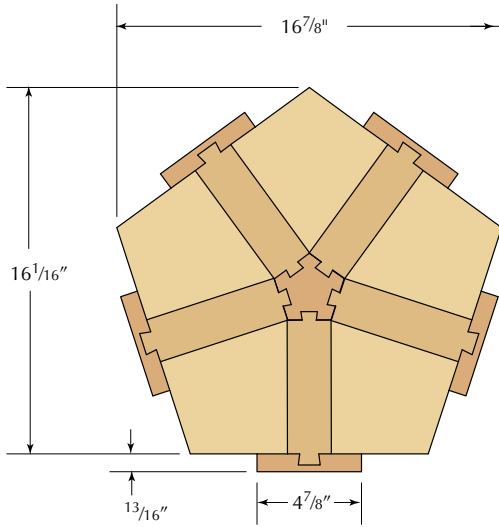

PLAN BELOW TOP

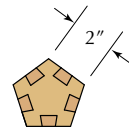

HUB PLAN

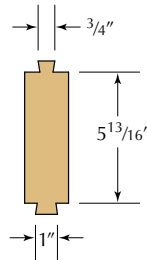

STRETCHER

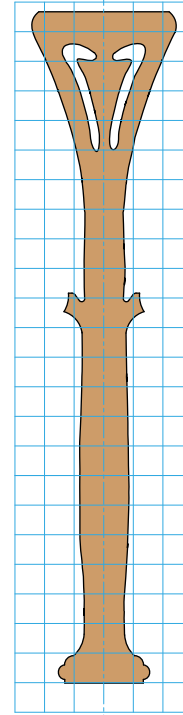

1 Square = 1"

LEG PATTERN

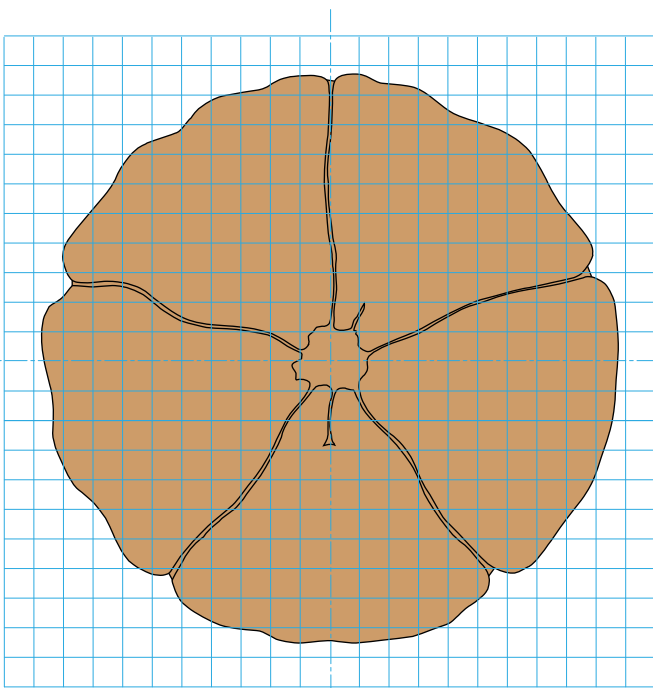

1 Square = 1"

TOP PATTERN

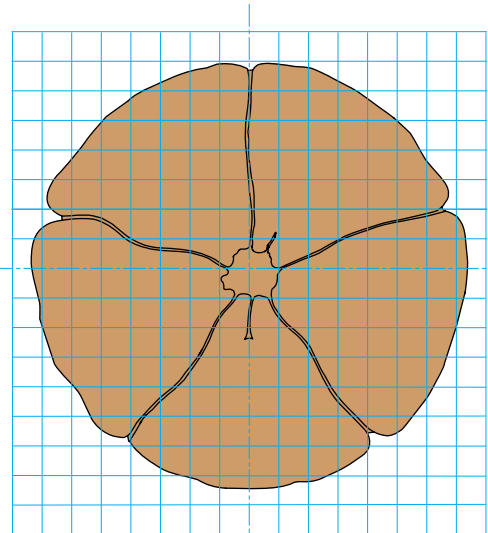

1 Square = 1"

SHELF PATTERN

Online EXTRAS

For additional photos and text, and to purchase full-size patterns in pdf format, go to:

popularwoodworking.com/dec07

A Little Carving

Before removing the paper pattern from the top and shelf, I traced the lines of the carving with the sharp point of my knife. After darkening these thin lines with a pencil, I used a 60° V-tool to establish the depth and sides of the lines. I followed that with a 1/8"-wide #11 gouge. The profile of the lines is mainly the profile of the U-shaped tool, so the only real challenge in carving was getting smooth, consistent lines.



Shape from the tool. After starting the carving with a V-tool, a deep, narrow gouge cleans up the cuts and defines the profile of the lines.

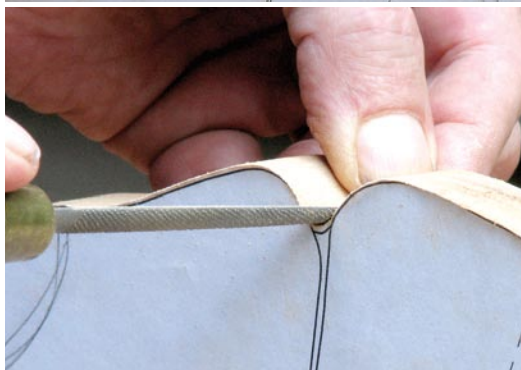
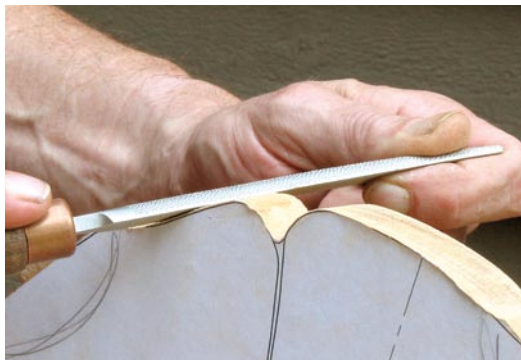

Rasp to the rescue. The flat side of this rasp removes the band-saw marks on most of the edge. The round side gets into places the flat side can't reach. Many of the finished tight curves are defined by the shape of the tool.

The lines that define the lobes were rounded slightly at the top with a skew chisel. The central portion of the carving is slightly domed. This is the only portion of the top surface that isn't flat. After carving, I smoothed the flat surfaces of the top with a plane, following up with a scraper and #240-grit Abranet (a new abrasive on a flexible mesh-like base that's not paper. Abranet cuts fast, leaves a smooth surface and doesn't load up).

Living on the Edge

The band-saw marks on the edges of the top and shelf were removed with a rasp. The edges were further refined with a modeler's rasp. One of the good things about using a hand-stitched rasp is that the surface left by the tool is a series of tiny grooves. A cabinet scraper quickly removes the high spots between the grooves, leaving a smooth surface.

The corners were broken with a few strokes of the fine-cut modeler's rasp, followed by sanding with a small piece of Abranet, folded to make a slight radius. When the top and shelf were complete, it was time to move on to the edges of the legs.

Another advantage to using the rasp is the ability to use the half-round side to shape inside curves as seen in the photo below at left. Many of the curves on this piece closely matched the curve of the rasps, so I believe that the original maker likely used the same technique and tools.

I used the same procedure and sequence of tools to smooth the edges of the legs and the cutouts at the top of each leg. The router bit left a decent surface, but there were a few chatter marks on long surfaces, and some burning in the tight inside corners. I wanted these edges to be as nice as the flat surfaces so I planned on it taking awhile.

Actually it took quite awhile. Smoothing the edges of the legs took about half the time I spent on this entire project. What slowed this step down were the tight corners at the buds on the legs, plus the cutout areas. In these places, the grain direction of the mahogany changes from long grain to end grain and then back again in the span of a few inches.

No one area was difficult to smooth, but the number of curves increased the overall length of the perimeter, and each area required a different approach. I found a stool to sit on, and settled in to get it right. When I was satisfied with the rasping and scraping, I went over the entire table with Abranet to obtain a consistent, smooth surface.



A close scrape. The hand-stitched rasp will leave shallow, narrow grooves. A cabinet scraper follows the rasp to remove the high spots between the grooves and leaves a fine surface.

Together at Last

I made one final dry assembly, screwed the legs to the shelf, then tapped the top stretchers into the tops of the legs. I marked the intersections of the shelf and legs, and carefully carved the shelf edges down to these points.

The final assembly was quick and painless. With screws holding the legs to the shelf, and the dovetails at the top of the legs, I didn't need any clamps. After applying glue to the end grain of the mortises in the legs, I applied glue to the tenon ends in the shelf, put the legs in place then drove the screws.

After making sure the legs were square to the shelf, I applied glue to the sockets at the top of the legs, then pushed and tapped the stretchers into place. Finally, the screw holes were filled with 3/8"-diameter mahogany plugs. After the glue in the plug holes was dry, I pared the plugs flush with the face of the leg using a 3/4" chisel. I then went over the face of each leg with my scraper and Abranet.

At the center of each stretcher, I drilled a 3/16"-diameter hole, and with the tabletop upside down on my bench, I lined up the assembled table base with the top. Each of the legs is centered in a lobe of the top, and the grain and pattern of the top is aligned with the shelf. In each of the five holes I drove a #8 x 1 1/4" washer-head screw. The holes are larger than the shanks of the screws, allowing the top to expand and contract.

I've seen original versions of this table in both mahogany and oak. Mahogany is a



Final cut. After shaping the legs and the shelf, the intersection is blended with a #1 straight carving chisel. Leaving these small areas oversized until almost the end of the project resulted in crisp detail in a highly visible place.

beautiful wood, and I wanted a finish that would show it off without filling the grain or looking polished. I used dark walnut Watco Danish oil for the first two coats and natural Watco Danish oil for the final three.

I applied the oil liberally, let it soak in for about 15 minutes, then reapplied more oil. I wet-sanded the table with a Scotch-Brite pad on the first coat, let it sit for another 10 minutes then wiped the surface dry. I waited a day between coats, then saturated the surface, allowed the oil to sit for 15 minutes, then wiped the surfaces dry.

Gustav Stickley's talent as a designer is often downplayed by those who aren't familiar with his entire career. The straight lines and masculine proportions of his Craftsman furniture can lead a person to believe that his entire body of work contains no curves or delicate shapes.

The Poppy Table was one of three similar tea tables produced in 1900. All three are exquisitely proportioned, sensitive designs based on floral forms. The style can be seen as a bridge between Art Nouveau and American Arts & Crafts. These early gems show that Gustav Stickley's tremendous talent for design was not dependent on the direction it was focused. **PW**

Bob is the author of several books about furniture from the Arts & Crafts period, including "Shop Drawings for Craftsman Furniture" (Fox Chapel). More information is available at his web site: craftsmanplans.com. Contact Bob by calling 513-531-2690 ext. 1327 or e-mail: robert.lang@fwpubs.com.



It isn't cheating. The original table had face-grain plugs in the faces of the legs. It is reasonable to assume that there are screws beneath the plugs. A Domino loose tenon reinforces these joints.



Last tap. The assembled hub and stretchers fit into the dovetail sockets at the top of the legs. When everything is lined up, they are tapped home, completing the assembly without using clamps.



First coat. Dark walnut Danish oil helps to accentuate the grain of the mahogany. Two color coats were followed by three coats of natural Danish oil.

Practical Safety Devices

by Marc Adams

I recently ran into an old woodworking friend of mine who had his hand all bandaged up, and the first thing he told me was: "I have new respect for my router table."

He went on to say that he was doing something that he knew was dangerous, had done it before and was sure he could get away with it again. The workpiece was definitely too short and sure enough it caught and pulled his hand into the cutter. The first thing I asked him was, "Were you using a push stick and was the guard in place?"

His head sank while his eyes looked at the top of his shoes and he uttered an embarrassed "no." He knew better and he was going to pay the price with a scar for the rest of his life. And even though his fingers were mauled and sore, he knew the accident could have been much, much worse. Throughout

Keep your guard up. To be safe in the shop, you need three things: guards that work, practical safety devices to assist your cuts and good rules to work by.



PHOTOS BY AL PARRISH

A Better Way to Work • Part 2

WOODWORKING Essentials